

## **Implementation of Direct AC-DC Boost Converter For Low Voltage Energy Harvesting**

S.Sendilkumar<sup>1</sup> V.Devaraj<sup>2</sup> R.Ravikumar<sup>3</sup> P.Hemkumar<sup>4</sup>  
V.Megala<sup>5</sup> G.Merlin subha<sup>6</sup> S.Amudhapriya<sup>7</sup>

*Professor<sup>1</sup>; Asst Prof<sup>2,4,5,6,7</sup> Department of EEE; Panimalar Engineering College;  
Poonamalli, Chennai 600123*

*Asso Prof<sup>3</sup> Department of EEE; Adhiyamaan College of Engineering,  
Hosur- 635109*

**ABSTRACT:** *In this paper, a direct AC-DC power electronic converter topology is proposed for efficient and optimum energy harvesting from low-voltage micro generators. The proposed converter use the bidirectional current conduction capability of MOSFET to avoid the use of front-end bridge rectifier which operates in discontinuous conduction mode. In the single inductor based direct AC-DC converters, external inductors are connected to the output of microgenerators for boost operation. This utilizes the coil inductance of electromagnetic microgenerators for boost operation. A suitable start-up circuit and auxiliary dc supply circuit is proposed for implementation of converter. This improves efficiency, reduces the component count and size of the converters and it is beneficial for circuit integration. The voltage across the load produced by low voltage micro generator is measured to study the performance of the system, thereby results are shown.*

**Keywords:** *Boost Converter, AC-DC Converter, Microgenerator, MOSFET*

### **I. INTRODUCTION**

A single stage DC-DC boost converter topology [1] of PWM-based switched inductor multilevel boost converter (SIMLBC) which combines the switched-inductor and capacitor provides a large output voltage with different output DC levels making it suitable for multilevel inverter applications. A new interleaved boost converter magnetically coupled to a voltage-doublers circuit providing voltage gain higher than that of the conventional boost topology suitable for the applications of grid connected systems based on battery storage and uninterruptible power system [2]. In this paper [3] a switching pulse-width modulated (PWM) DC-DC converter performance is studied under the influence of random noise. They experimentally verify existence of noise and measure its statistical properties on the operating characteristics of the boost converter. The discontinuous current mode boost power factor correction (PFC) converter [4] automatically achieves PFC by keeping duty cycle is constant in line cycle; however, there is large third harmonic input current in respect of the fundamental component. Therefore, the input power factor is low, and a large storage capacitor is needed. Injecting appropriate third harmonic with initial phase of zero into the input current could reduce the storage capacitor. A method of fitting the duty cycle is further proposed for simplifying the circuit implementation. A positive buck-boost converter known as DC-DC converter which controlled to act as buck or boost converter with same polarity of the input voltage.[5] This converter has four switching states which include all the switching states of the above mentioned DC-DC converters. In addition there is one switching state that provides a degree of freedom for the positive buck-boost converter in comparison to the buck, boost, and inverting buck-boost converters. In other words the positive buck-boost converter shows a higher level of flexibility for its inductor current control compared to the other DC-DC converters. In this paper this extra degree of freedom is utilized to increase the robustness against input voltage fluctuations and load changes. To address this capacity of the positive buck-boost converter, two different control strategies are proposed which control the inductor current and output voltage against any fluctuations in input voltage and load changes. An adaptive controller for the compensation of output voltage ripple[6] due to harmonic distortion in the input voltage is proposed for a pulse width modulated (PWM) boost converter. To facilitate the implementation, the authors have tried to preserve the structure of the proposed controller as close as possible to the conventional one, which includes a voltage outer loop (basically a proportional plus integral (PI) control on the output voltage error) and an inner control loop (basically a proportional control plus a feed forward term). A family of isolated buck-boost DC-to-DC converter[7] for wide input-voltage range is proposed in this paper, and the full-bridge (FB) boost converter, being one of the typical topologies, is analyzed. The conventional power electronics converters used for some

applications have two stages, a diode bridge rectifier at the front end followed by a DC-DC boost converter. However, the extremely low output voltage of electromagnetic microgenerators does not allow diode bridge rectification. Even if possible, the losses in the front end diode bridge make the conventional power electronic interfaces quite inefficient. The proposed single stage converters directly boost the microgenerator low ac voltage to usable dc voltage level, and hence, achieve higher efficiency. The single stage AC-DC power conversion is achieved by utilizing the bidirectional current conduction capability of MOSFETs. Moreover, for optimum energy harvesting the power converter should be able to control the load resistance as seen by a microgenerator. Here, a direct AC-DC power converter is proposed for efficient energy harvesting from the low voltage inertial microgenerators. The conventional power converters use diode bridge rectifiers and condition the microgenerator outputs in two stages. Hence, they are inefficient and may not be a feasible option for very low voltage microgenerators. Moreover, they are not conducive for optimum energy harvesting. The proposed converter avoids the use of bridge rectifiers, and directly converts the ac input to the required dc output. This converter uses a boost converter and a buck-boost converter to process the positive and negative half cycles of the ac input voltage, respectively. Furthermore, using this converter, maximum energy harvesting can be implemented effectively. Analysis of the converter is carried out. Based on the analysis, two schemes, which is the open loop and closed loop circuit, are proposed to control the converter.

## II. OBJECTIVE OF THE WORK

- The main objective of this work is converting a low AC voltage to a very high DC voltage without the use of front-end bridge rectifiers.
- The conduction losses in the diodes experienced in the conventional methods are eliminated in the proposed method. In addition, uncharged balances in the capacitors are avoided.
- Since the proposed method uses bidirectional capability of MOSFET, it offers a linear load reduces switching losses and provides a constant duty cycle and as a result, we get a high DC voltage that can be used for low voltage energy harvesting.

## III. SYSTEM STUDIED FOR CONVENTIONAL METHODS

### 3 a(i) Two Power Stage Converter

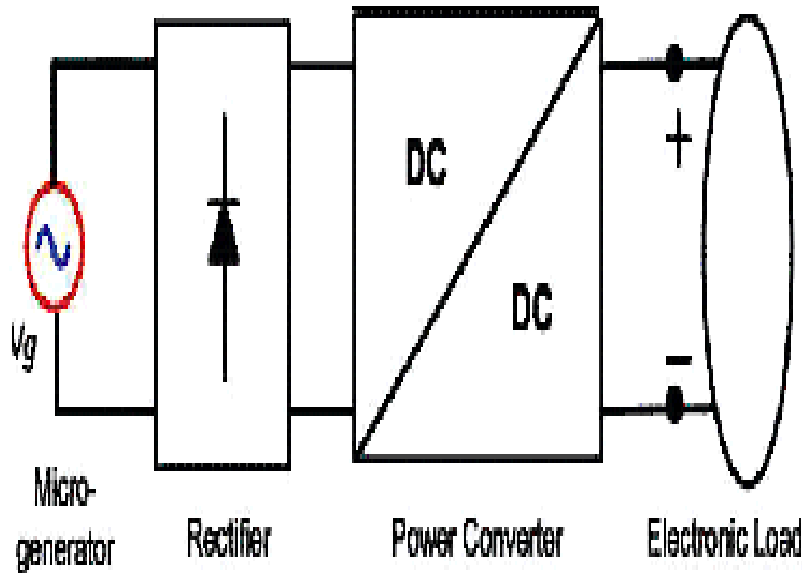

**Figure.1: Block diagram of two stage power converter**

**Figure 1** shows two stage power converter here conversion takes places individually [ ]. The circuit consists of a front end bridge rectifier which is followed by a standard buck or boost converter. The supply is given from a microgenerator, particularly electro magnetic microgenerators, due to its high energy density. Such microgenerators are typically spring-mass systems, in which mechanical energy is converted to electrical energy by electromagnetic damping. The output of an inertial micro generator is typically around a few hundred millivolts AC.

3a(ii) Dual boost converter

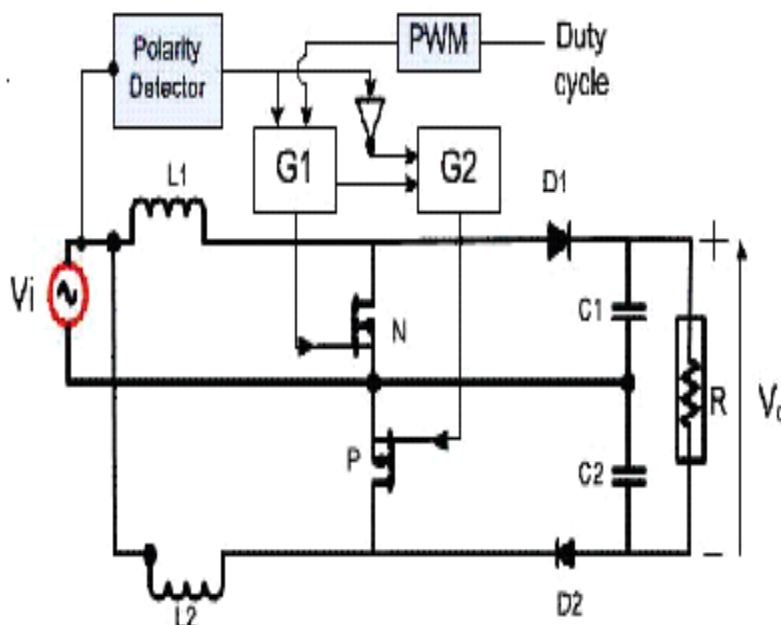

Figure 2 System for dual boost power converter

In Figure 2 dual boost power converter is given in which the converter uses two inductors and the output DC bus is split into two series connected capacitors. The fundamental principle is that each boost converter operates in one half cycle of the AC voltage. Each capacitor is charged only in the respective half cycle. However, they discharge to the load continuously causing large voltage drop. Extremely large capacitors are needed to make the voltage ripple acceptable so the response becomes slow.

IV. SYSTEM STUDIED FOR THE PROPOSED METHOD USING MOSFET

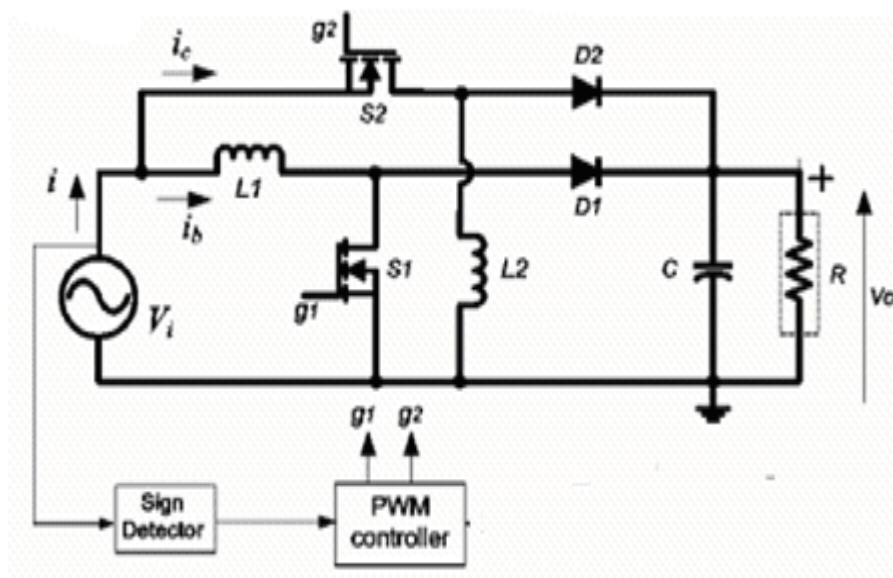
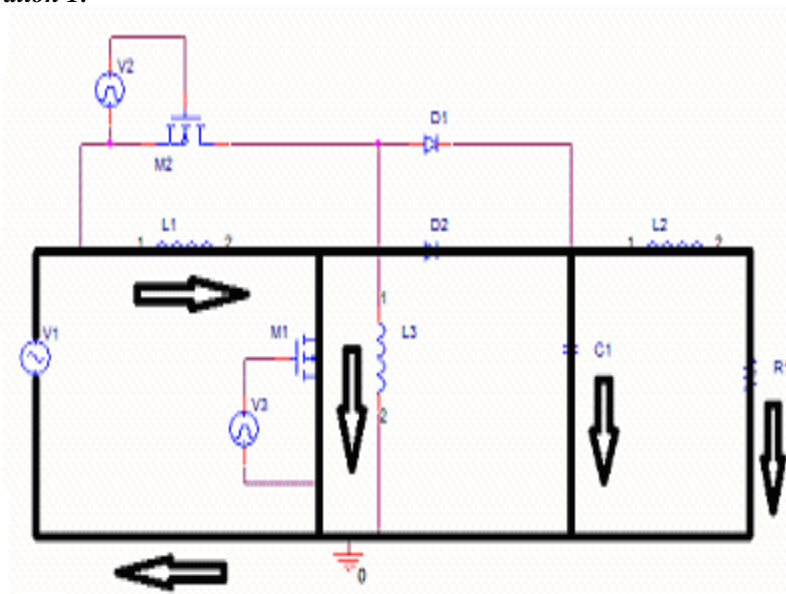

Figure.3 Circuit for proposed method using MOSFET

In this paper the work for the proposed method is given in the Figure.3 presents an efficient AC to DC power converter that avoids the bridge rectification and directly converts the low ac input voltage to the required high dc output voltage at a higher efficiency. The proposed converter have boost converter in parallel with a buck-boost converter, which is operated in the positive half cycle and negative half cycle respectively. It utilizes an n and p-type MOSFET pair to form a bi-directional switch. However a single semiconductor device capable of both bidirectional conduction and blocking capability does not exist. A MOSFET channel is capable of

conduction in both directions when it is sufficiently turned ON. Bidirectional switch is realized by connecting drain of n-MOSFET to the source of p-MOSFET so that their body diodes block current in opposite directions. The converter operates in discontinuous conduction mode. The circuit given in Figure.3 operates on different operation modes and they are

**a(i) Modes of operation 1:**



**Figure.4: Operation of positive half cycle**

In the Figure.4 the inductor current increases linearly from zero when the switch is turned ON when switch is turned OFF the body diodes block the circulating current. The diode D1 is forward biased and current flows into the capacitor to complete the charging process.

**a(ii) Mode of operation 2**

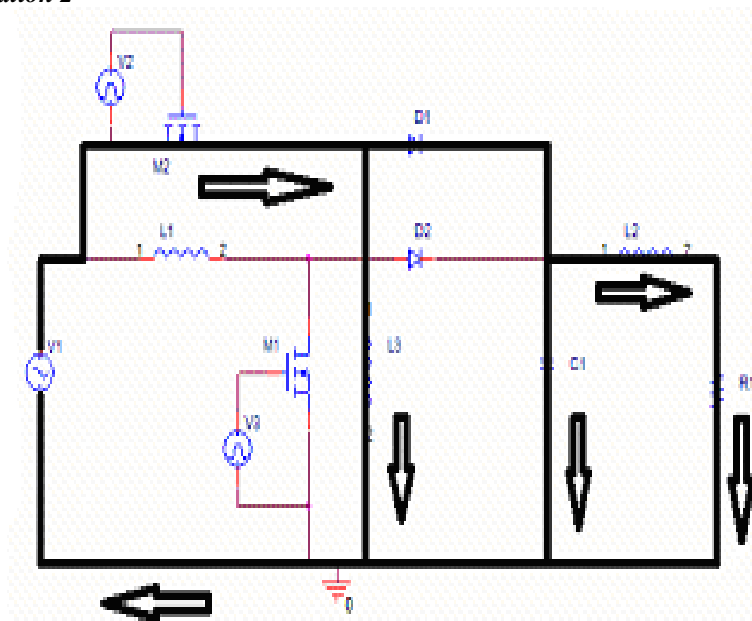
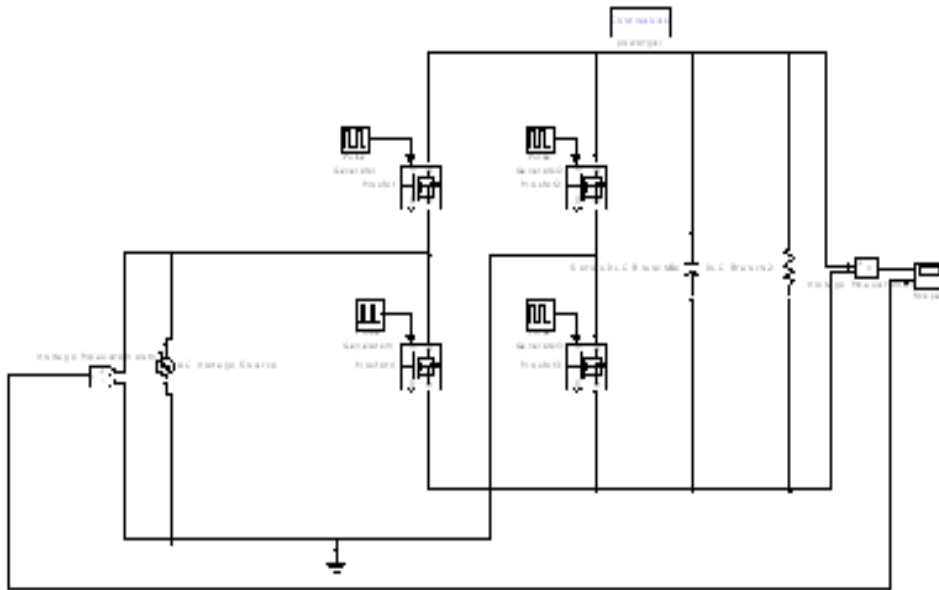

**Figure.5: Operation of negative half cycle**

In the Figure.5 it describes the current rises in the opposite direction when switch is turned ON. However this time when switch is turned OFF, diode D1 remains off and diode D2 is forward biased. The inductor energy is transferred to capacitor and the negative gain of the buck–boost converter is utilized to boost the voltage of the negative half cycle of the micro generator to positive dc voltage. A self-startup circuit, using a battery only during the beginning of the converter operation, is proposed for the energy-harvesting converter.

V. SIMULATION RESULTS

5a(i) Two stage converter



a) Model of Two Stage Oscillatory

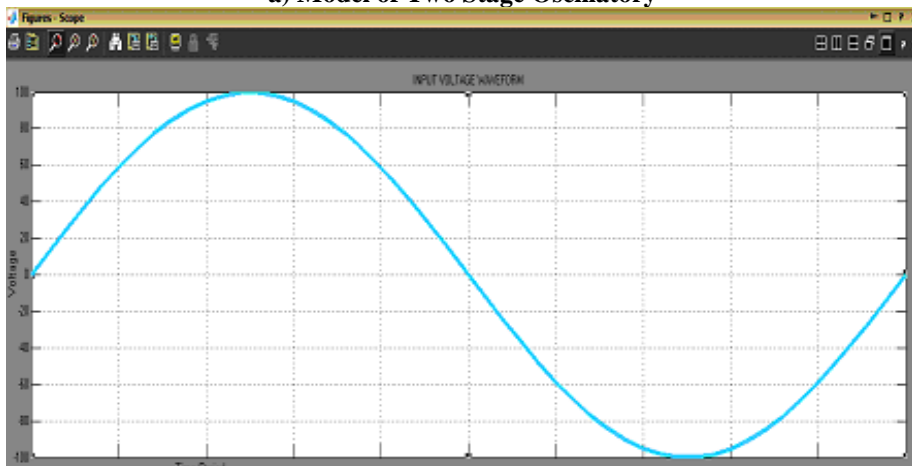

b) Input waveform

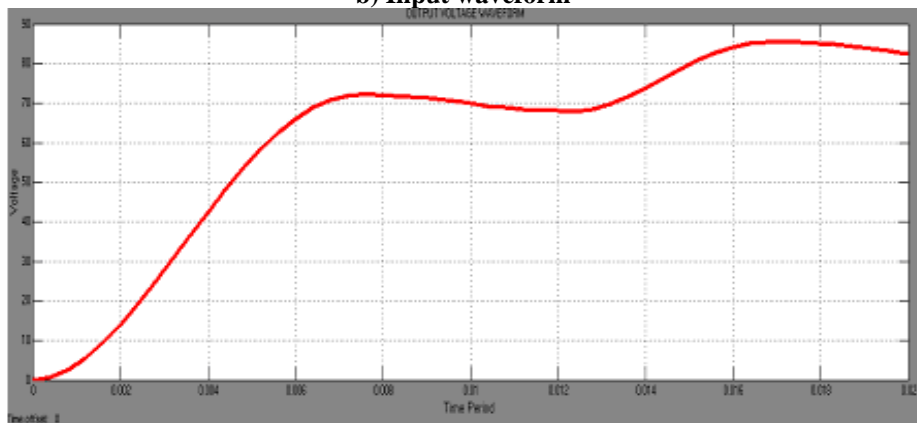

c) Output waveform

Figure 7: Performance of two-stage converter

Figure.7 show the model for two stage converter in which the input is AC supply and the output measured across the load is given in the Figure 7 it is found the voltage is oscillatory.

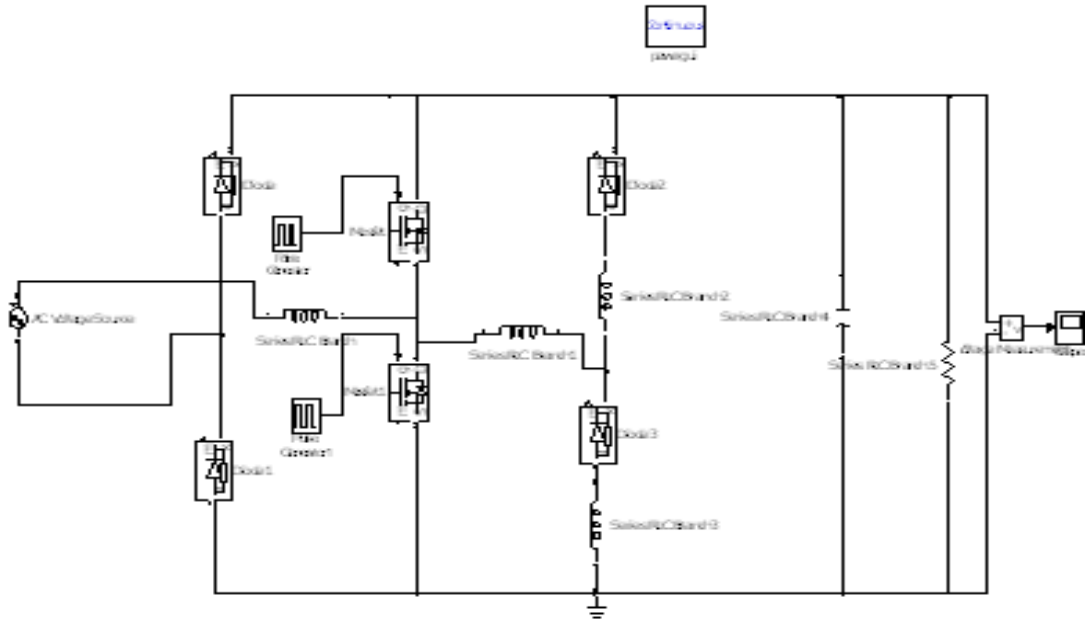

a) Modal of dual boost converter

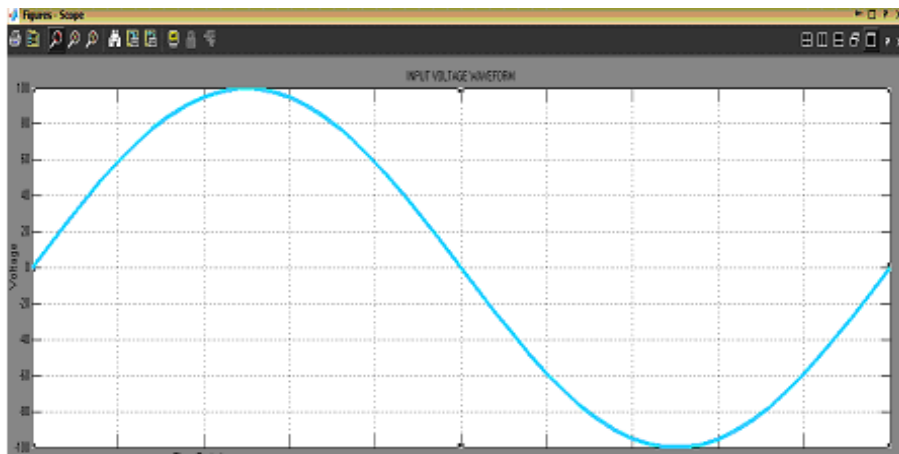

b) Input waveform

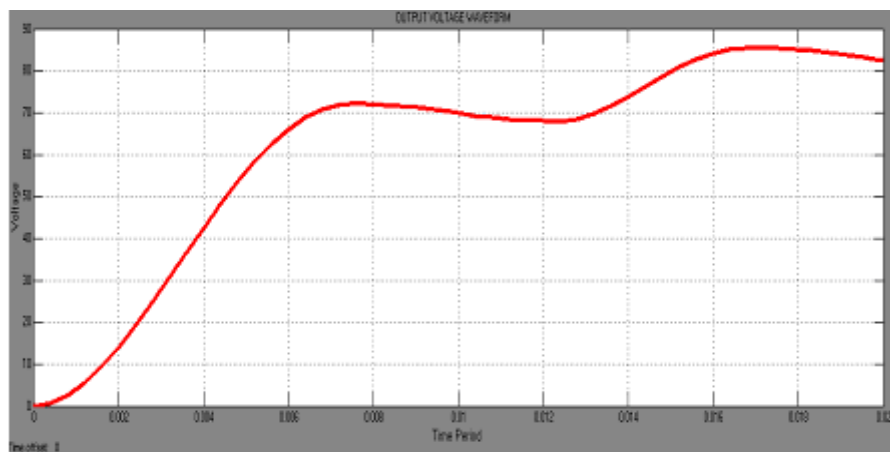

c) Output waveform

Figure 8 Performance of dual boost converter

Figure.8 shows the performance of dual converter and the input given is ac supply and the output measured across the load is given in Figure 8c.

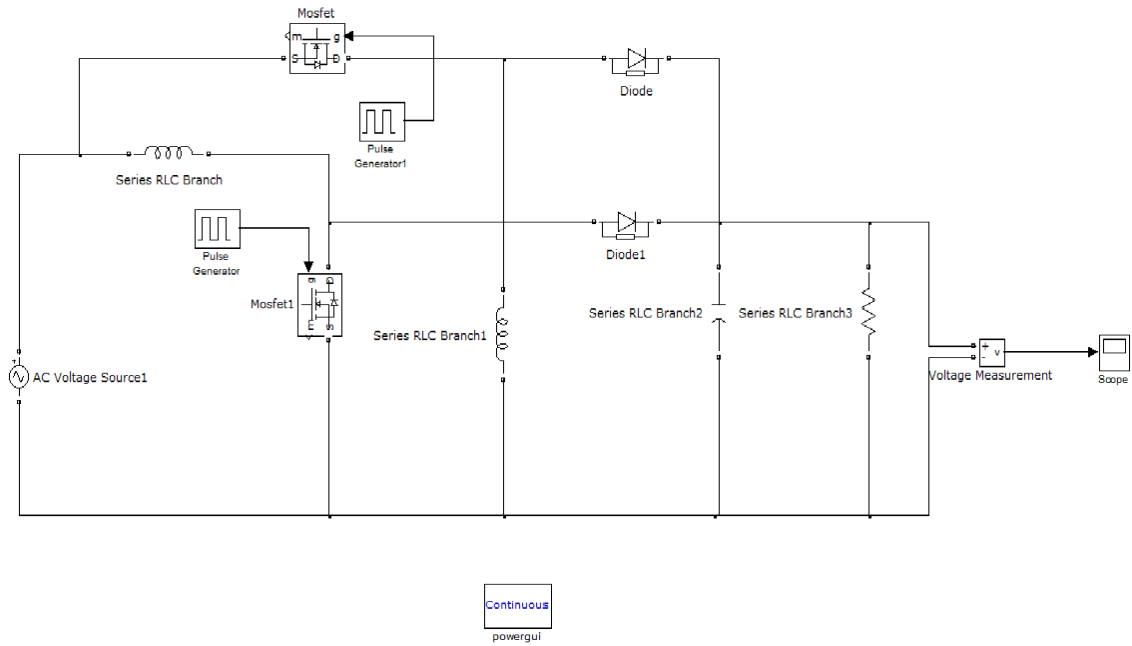

a) Modal of MOSFET based converter

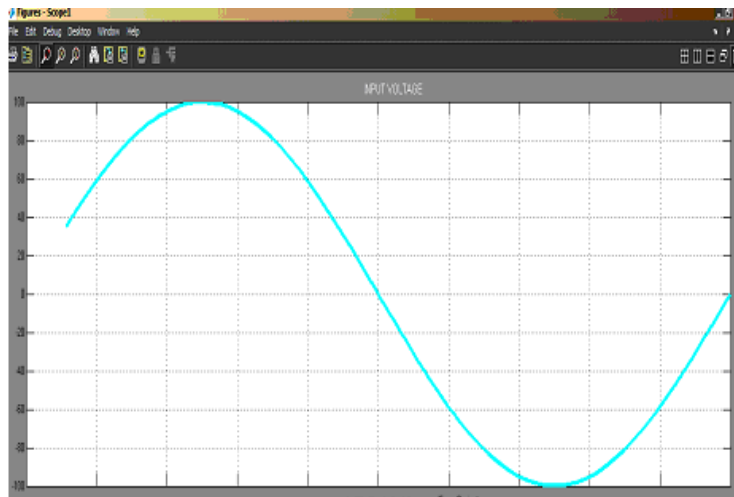

b) Input waveform

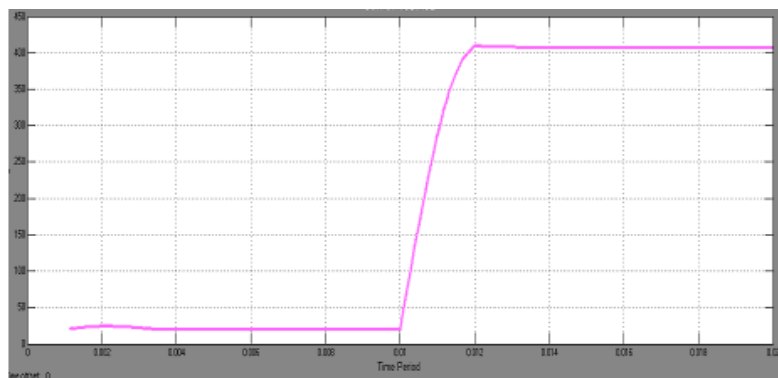

c) Output waveform without PI controller

Figure 9 Performance of MOSFET based converter for open loop

**Figure 9** Shows the performance of the proposed model for open. In open loop the voltage measured across the load reaches the stable state at 400 V for the given 100V.

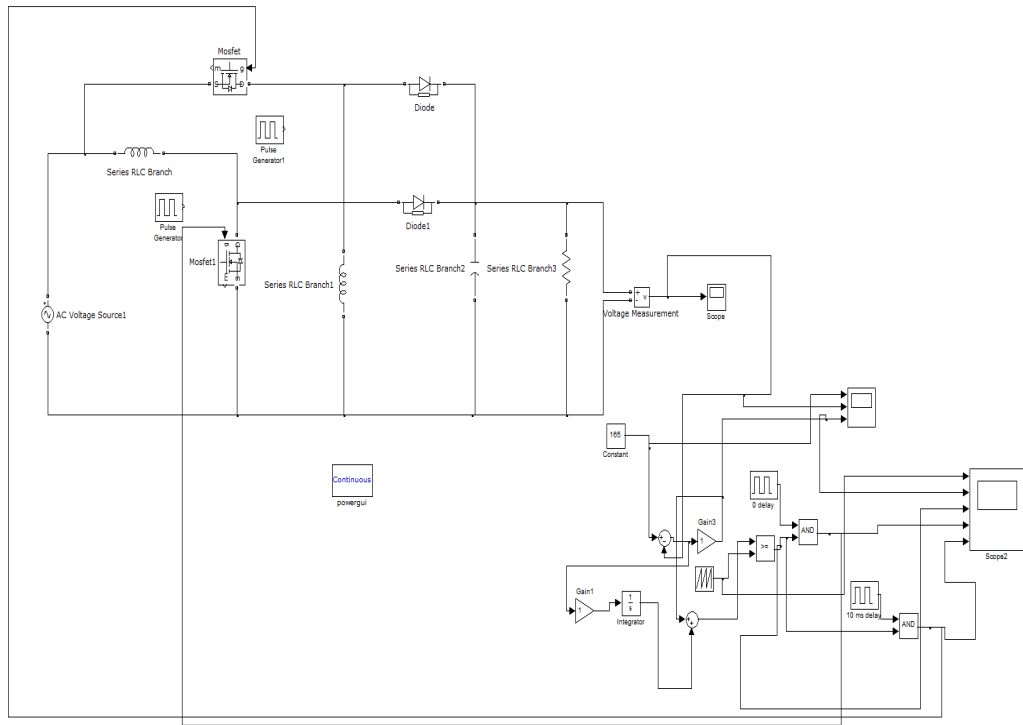

a) Model of closed loop control

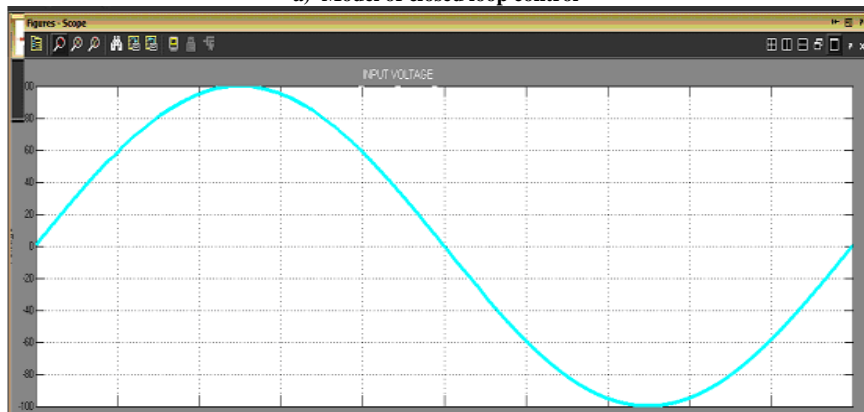

b) Input waveform

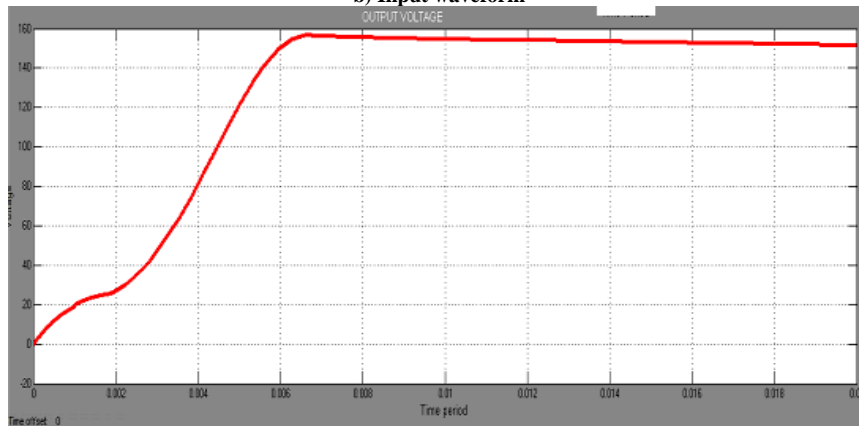

c) Output waveform of converter with PI controller

**Figure 10** Performance of MOSFET based converter for closed loop



**Table .1 Performance of Boost converter of closed loop**

**Figure 10** Shows the performance of the proposed model of closed loop and the voltage measured across the load is constant through out the cycle.

<b>Simulation result of boost converter</b>	<b>Input voltage (V)</b>	<b>Output voltage (V)</b>
	<b>100</b>	<b>407</b>

## VI. CONCLUSION

In this paper the proposed method of AC-DC boost converter for low power factor, low voltage energy harvesting is presented. A bidirectional switch, based on series connected n-MOSFET and p-MOSFET is proposed. The converter utilizes bidirectional switch to boost the low AC microgenerator voltage to a steady DC voltage in both the input half cycles. Experimental results for a low voltage micro generator have been proposed to verify the operation of the converter and the proposed auxiliary circuits. The designed auxiliary circuits draw minimal power and are able to operate the converter at a higher efficiency.

## VII. ACKNOWLEDGMENT

The authors are thankful to the management of Panimalar Engineering College Chennai for providing all the computational facilities to carry out this work.

## REFERENCES

- [1]. M.El-Hami, P. Glynn-Jones, N.M.White, M.Hill, S.Beeby, E.James,A.D.Brown and J.N.Ross, Design and fabrication of a new vibration-based electromechanical power generator. *Sensors and Actuators, A: Physical*, 18(2), 2001, 335–342.
- [2]. A. Sangswang, C.O. Nwankpa, C.O Performance evaluation of a boost converter under influence of random noise a. *Proceedings of PESC, 2003*, 927-931.
- [3]. G.A.L Henn, R.N.A.L Silva, P.P. Praça, L.H.S.C Barreto, D.S Oliveira, Interleaved-Boost Converter With High Voltage Gain, *IEEE Transaction on Power Electronics*,25(11),2010,2753-2761.
- [4]. Kai Yao, Xinbo Ruan, Xiaojing Mao, Zhihong Ye, *Reducing Storage Capacitor of a DCM Boost PFC Converter*, *IEEE Transaction on Power Electronics*,25(11),2012 ,151-160.
- [5]. A. A Boora, F.Zare, G.Ledwich, A.A.Ghosh, A general approach to control a Positive Buck-Boost converter to achieve robustness against input voltage fluctuations and load changes, *Proceedings of PESC 2008*,2011-2017.
- [6]. G.Escobar, A.A Valdez, J.Leyva-Ramos, P.R. Martinez A controller for a boost converter with harmonic reduction, *IEEE Transaction on Control Systems and Technology*, ,12(5), 2004,717-726.
- [7]. Chuan Yao, Xinbo Ruan, Xuehua Wang, C.K. Tse Isolated Buck–Boost DC/DC Converters Suitable for Wide Input-Voltage Range, *IEEE Transaction on Power Electronics*,26(9),2011,25992613